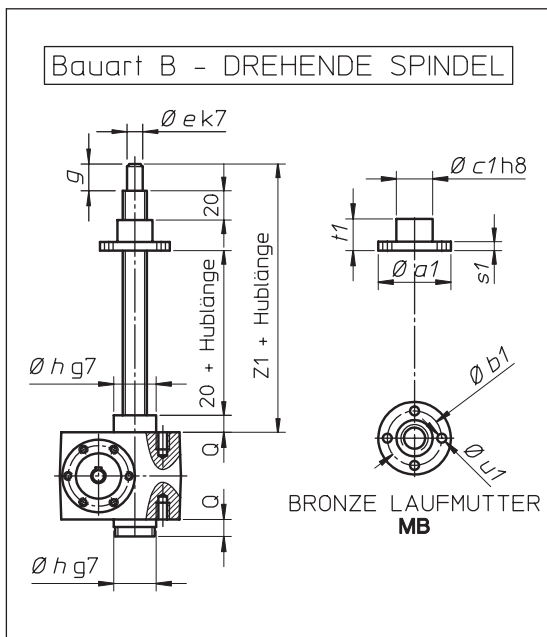
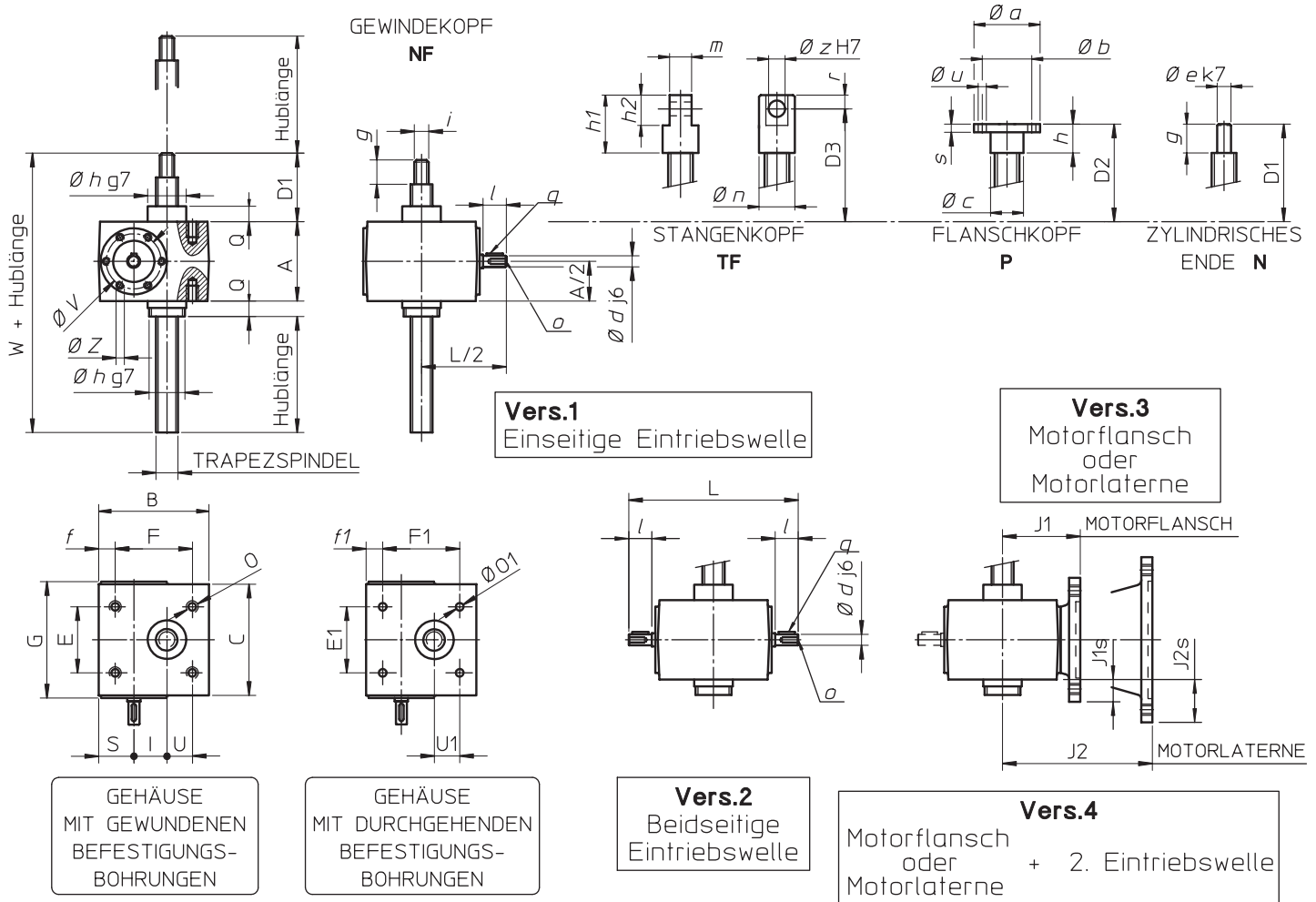
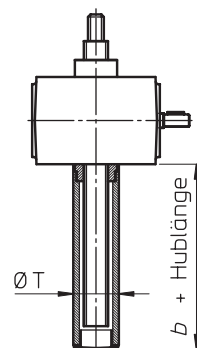
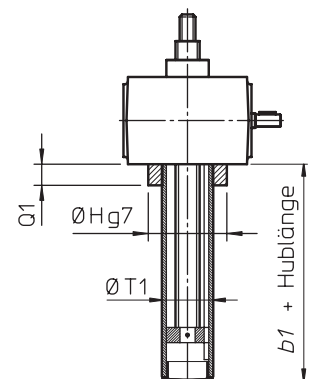
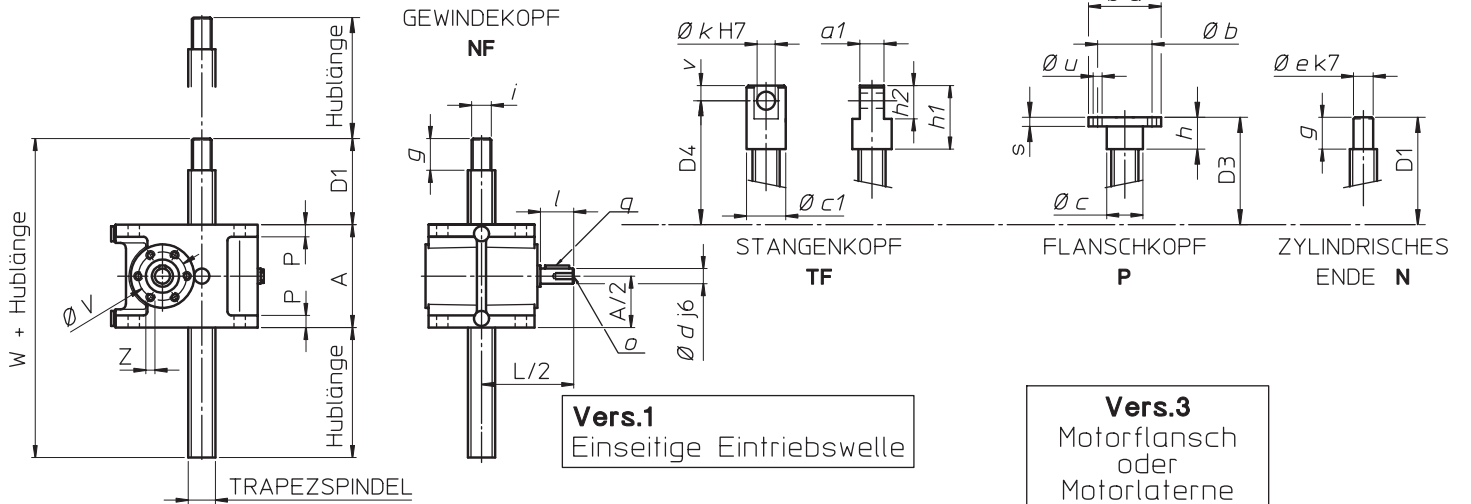

BAUGRÖSSE	SJ 5	SJ 10	SJ 25	SJ 50	SJ 80	SJ 200	
TRAPEZSPINDEL	Tr 18 × 4	Tr 22 × 5	Tr 30 × 6	Tr 40 × 7	Tr 55 × 9	Tr 70 × 12	Tr 80 × 12
A	62	76	82	118	160	176	
B	100	110	160	200	220	280	
C	86	96	130	160	170	230	
D1 (eingefahren)	51	62	81	90	108	118	
D2 (eingefahren)	52	63	83	92	110	120	
D3 (eingefahren)	77	93	118	137	160	210	
E	52	63	81	115	134	180	
E1	56	80	102	130	120	180	
F	60	78	106	150	175	230	
F1	80	85	131	165	180	230	
G	90	100	136	165	165	-	
I	25	30	50	63	63	90	
L	135	165	221.5	269	269	350	
O (Gewinde × Tiefe)	M8 × 14	M8 × 15	M10 × 15	M12 × 16	M20 × 30	M30 × 45	
Ø O1	9	9	11	13	17	26.5	
Q	12	18	23	32	40	40	
S	37	40	50	59	74	75	
U	21	29	42	63	60	90	
U1	28	30	48	60	63	90	
Ø V	46	46	64	63	63	-	
W	125	156	186	240	308	334	
Z (Gewinde × Tiefe)	M6 × 13 (4 Bohr.)	M5 × 10	M5 × 10	M6 × 14	M6 × 14	-	
Z1	111	127	151	185	228	268	248
Ø a	68	75	100	120	150	180	
Ø a1	68	75	100	120	130	180	190
Ø b	45	55	75	85	110	130	
Ø b1	50	56	75	90	105	140	150
Ø c	25	30	40	50	70	85	
Ø c1	30	40	50	60	75	100	110
Ø d	9	14	19	24	24	30	
Ø e	12	15	20	30	40	50	60
f	23	21	36	35	22	25	
f1	10	15	17	17	20	25	
g	19	24	38	38	48	58	
h	20	25	40	40	50	60	
Ø h	30	38.7	46	60	90	120	
h1	60	75	100	120	140	210	
h2	30	40	50	70	80	120	
i	M12 × 1.75	M16 × 1.5	M20 × 1.5	M30 × 2	M42 × 3	M56 × 3	
l	20	30	40	50	50	55	
m	20	25	30	40	50	75	
Ø n	32	38	48	68	78	108	
o (Gewinde × Tiefe)	M4 × 8	M6 × 14	M8 × 16	M8 × 16	M8 × 16	M10 × 18	
q	3 × 3 × 15	5 × 5 × 20	6 × 6 × 30	8 × 7 × 40	8 × 7 × 40	8 × 7 × 45	
r	15	20	25	35	40	60	
s	8	10	12	15	20	25	
s1	12	12	15	25	20	35	30
t1	40	45	50	75	100	130	110
Ø u × Nr. Bohr.	Ø 7 × 4	Ø 9 × 4	Ø 11 × 4	Ø 17 × 4	Ø 21 × 4	Ø 26 × 6	
Ø u1 × Nr. Bohr.	Ø 7 × 4	Ø 9 × 4	Ø 11 × 4	Ø 17 × 4	Ø 17 × 4	Ø 26 × 6	Ø 18 × 4
Ø z	14	20	25	35	40	60	
J1	56 B5/B14: 57.5	63 B5/B14: 62	63/71 B5: 102	80 B5: 100	80 B5: 100	100/112 B5: 170	
J1s	56 B5: 29 56 B14: 9	63 B5: 37 63 B14: 7	63 B5: 29 71 B5: 39	80 B5: 41	80 B5: 20	100/112 B5: 37	
J2	63 B5: 98	71 B5: 122 71 B14: 131	80 B5: 182 80 B14: 176 90 B5: 182 90 B14: 182	90 B5: 200 90 B14: 200 100 B5: 220 100 B14: 220	90 B5: 200 90 B14: 200 100/112 B5: 220 100/112 B14: 220	-	
J2s	63 B5: 39	71 B5: 47 71 B14: 15	80 B5: 59 80 B14: 19 90 B5: 59 90 B14: 29	90 B5: 41 90 B14: 11 100 B5: 66 100 B14: 21	90 B5: 20 90 B14: - 100/112 B5: 45 100/112 B14: -	-	

Baureihe SJ
Bauart A - HEBENDE SPINDEL

SCHUTZROHR T

VERDREHSICHERUNG AR

BAUGRÖßE	SJ 5	SJ 10	SJ 25	SJ 50	SJ 80	SJ 200
ØT	35	40	50	65	102	130
b	Ausführung T	37	43	48	57	65
	Ausf. T + SN	87	93	128	137	155
	Ausf. T + FCM	86	93	98	-	-
	Ausf. T + FCP	87	93	98	107	115
ØH	55	70	85	115	-	-
Q1	21	18	25	32	-	-
ØT1	45	55	70	90	100	140
b1	Ausf. AR	86	88	105	112	165
	Ausf. AR + FCP	96	98	115	132	175

Bauart A - HEBENDE SPINDEL



Vers.1
Einseitige Eintriebswelle

Vers.3
Motorflansch
oder
Motorlaterne

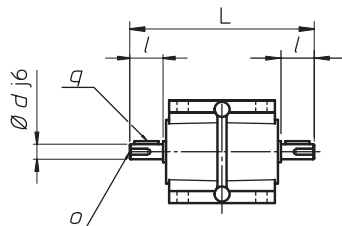
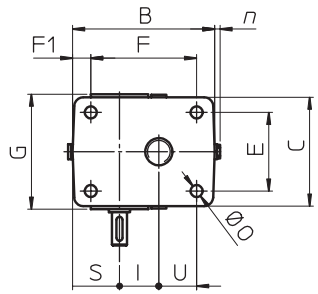

Vers.2
Beidseitige Eintriebswelle

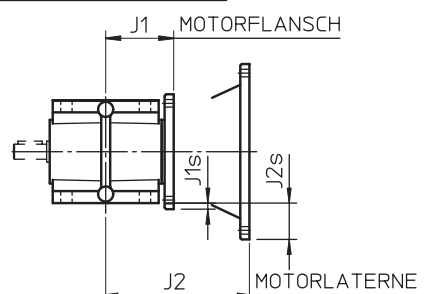

Vers.4
Motorflansch
oder + 2. Eintriebswelle
Motorlaterne

SCHUTZROHR T

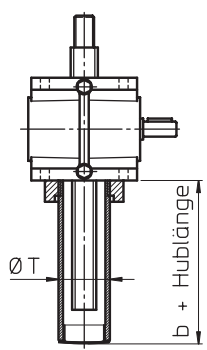

BRONZE FÜHRUNGSBÜCHSE

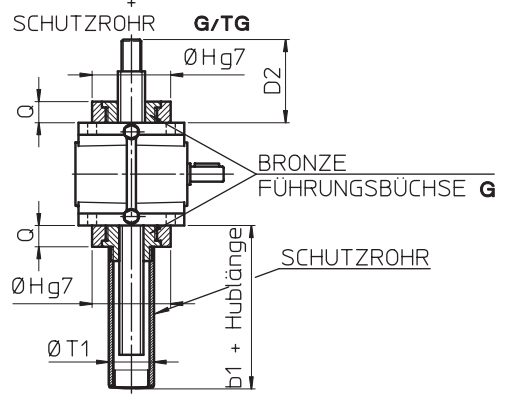

Bauart B - DREHENDE SPINDEL

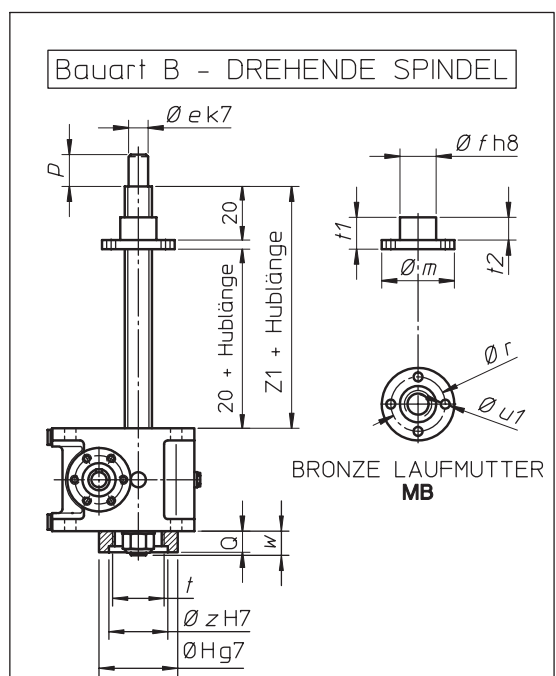

BAUGRÖßE	MA 5	MA 10	MA 25	MA 50	MA 80	MA 100	MA 200	MA 350
ØT	45	55	70	90	90	110	150	180
Ausführung T	25	25	25	25	25	35	35	35
Ausf. T + SN	75	75	105	105	115	105	115	135
Ausf. T + AR	80	85	95	105	125	115	145	175
Ausf. T + FCM	82	86	-	-	-	-	-	-
Ausf. T + FCP	85	86	94	96	96	100	105	110
Ausf. T+AR+FCP	90	96	114	126	146	140	175	210
ØT1 (*)	36 (40)	45 (50)	55	55	90	90	90	160
Ausführung TG	50	51	59	61	61	65	90	125
b1 Ausf. TG + FCM	100	101	115	-	-	-	-	-
Ausf. TG + FCP	100	101	109	111	111	115	140	165

(*) - Die Werte ØT1 in Klammer beziehen sich auf die Ausführung TG + FCP

Baureihe MA

Maße

BAUGRÖSSE	MA 5	MA 10	MA 25	MA 50	MA 80	MA 100	MA 200	MA 350
TRAPEZSPINDEL	Tr 18 × 4	Tr 22 × 5	Tr 30 × 6	Tr 40 × 7	Tr 55 × 9	Tr 60 × 12	Tr 70 × 12	Tr 100 × 16
A	80	100	126	160	160	200	230	280
B	124	140	175	235	235	276	330	415
C	80	105	130	160	160	200	230	300
D1 (eingefahren)	39	44	58	58	68	68	78	98
D2 (eingefahren)	54	60	82	84	94	98	113	138
D3 (eingefahren)	40	45	60	60	70	70	80	100
D4 (eingefahren)	65	75	95	105	120	150	170	220
E	62	80	100	120	120	150	175	230
F	95	110	140	190	190	220	270	330
F1	12.5	14	17.5	23	23	26	30	42
G	100	114	136	165	165	205	256	326
∅ H	65	80	100	120	120	160	190	240
I	30	40	50	63	63	80	100	125
L	149	179	221.5	269	269	330	378	490
∅ O	9	9	13	17	17	21	28	34
P	10	12	15	19	19	22	26	30
Q	15	16	24	26	26	30	35	40
S	46.5	46	57.5	80	80	91	113	121
U	31	38	50	70	70	75	87	126
∅ V	42	46	64	63	63	74	110	118
W	119	144	184	218	228	268	308	378
Z (Gew. × Tiefe)	M5 × 10	M5 × 12	M5 × 10	M6 × 14	M6 × 14	M6 × 14	M10 × 20	M10 × 25
Z1	80	85	90	115	140	140	170	200
∅ a	68	75	100	120	150	150	180	250
a1	20	25	30	40	50	60	75	100
∅ b	45	55	75	85	110	110	130	180
∅ c	25	30	40	50	70	70	85	115
∅ c1	32	38	48	68	78	90	108	138
∅ d	10	14	19	24	24	28	32	38
∅ e	12	15	20	30	40	40	50	70
∅ f	30	40	50	60	75	80	100	150
g	19	24	38	38	48	48	58	78
h	20	25	40	40	50	50	60	80
h1	60	75	100	120	140	180	210	280
h2	30	40	50	70	80	100	120	160
i	M12 × 1.75	M16 × 1.5	M20 × 1.5	M30 × 2	M42 × 3	M42 × 3	M56 × 3	M80 × 3
∅ k	14	20	25	35	40	50	60	80
l	22	30	40	50	50	60	60	80
∅ m	68	75	100	120	130	150	180	250
n	-	-	10	10	10	12	10	10
o (Gew. × Tiefe)	M5 × 10	M6 × 14	M8 × 16	M8 × 16	M8 × 16	M8 × 16	M10 × 24	M12 × 32
p	19	24	40	40	45	50	60	65
q	3 × 3 × 15	5 × 5 × 20	6 × 6 × 30	8 × 7 × 40	8 × 7 × 40	8 × 7 × 40	10 × 8 × 40	10 × 8 × 60
∅ r	50	56	75	90	105	120	140	200
s	8	10	12	15	20	20	25	35
t	M45 × 1.5	M55 × 1.5	M70 × 2	M90 × 2	M90 × 2	M110 × 2	M150 × 3	M180 × 3
t1	40	45	50	75	100	100	130	160
t2	28	33	35	50	80	70	95	115
∅ u × Nr. Bohr.	∅ 7 × 4	∅ 9 × 4	∅ 11 × 4	∅ 17 × 4	∅ 21 × 4	∅ 21 × 4	∅ 26 × 6	∅ 30 × 6
∅ u1 × Nr. Bohr.	∅ 7 × 4	∅ 9 × 4	∅ 11 × 4	∅ 17 × 4	∅ 17 × 4	∅ 21 × 4	∅ 26 × 6	∅ 30 × 6
v	15	20	25	35	40	50	60	80
w	15	17	25	36	38	41	42	45
∅ z	50	60	77	95	95	120	160	200
J1	62	69	102	100	100	120	142	-
J1s	63 B5: 30 63 B14: 5	63 B5: 20 63 B14: -	63 B5: 7 71 B5: 17	80 B5: 20	80 B5: 20	80 B5: - 90 B5: -	90 B5: - 100/112 B5: 10	-
J2	71 B5: 122 71 B14: 131	71 B5: 129 71 B14: 138	80/90 B5: 182 80 B14: 176 90 B14: 182	90 B5/B14: 200 100 B5/B14: 220	90 B5/B14: 200 112 B5/B14: 220	100/112 B5: 240 100/112 B14: 240	132 B5: 297	-
J2s	71 B5: 40 71 B14: 13	71 B5: 30 71 B14: 3	80/90 B5: 37 80 B14: - 90 B14: 7	90 B5: 20 100 B5: 45 90/100 B14: -	90 B5: 20 112 B5: 45 B14: -	112 B5: 25 112 B14: -	132 B5: 35	-